

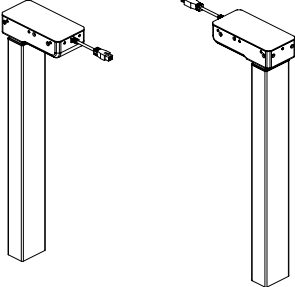







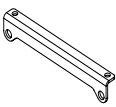

# Assembly & Installation Instructions: Ascent4 2-Leg Work Center

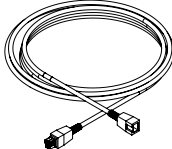
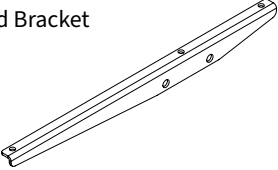
AS4EX-30-48-FXX-PS-X, AS4LX-30-48-FXX-PS-X

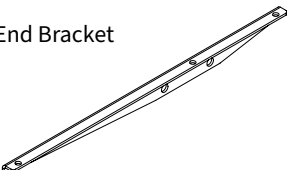
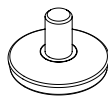
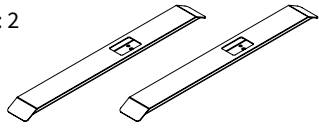
## Parts Included

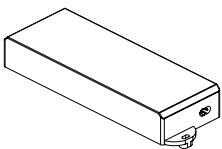
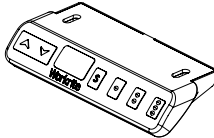
<p><b>A</b> Leg Qty: 2</p> 	<p><b>G</b> #12 × 3/4" Pan Head Screw Qty: 21</p> 	<p><b>N</b> 3/16" Cable Loops Qty: 5</p> 
<p><b>B</b> Short Bracket Qty: 4</p> 	<p><b>H</b> M8 × 18 mm Flat Head Cap Screw Qty: 4</p> 	<p><b>O</b> Motor Cable Qty: 1</p> 
<p><b>C</b> Left End Bracket Qty: 1</p> 	<p><b>I</b> 5 mm Allen Wrench Qty: 1</p> 	<p><b>P</b> Power Cord Qty: 1</p> 
<p><b>D</b> Right End Bracket Qty: 1</p> 	<p><b>J</b> Glide Qty: 4</p> 	<p><b>Q</b> Feet Qty: 2</p> 
<p><b>E</b> 4 mm Allen Wrench Qty: 1</p> 	<p><b>K</b> Control Box Qty: 1</p> 	<p><b>R</b> Programmable Switch Qty: 1</p> 
<p><b>F</b> M6 × 14 mm Flat Head Cap Screw Qty: 12</p> 	<p><b>M</b> #8 × 5/8" Pan Head Screw Qty: 7</p> 	

## Worksurface Required, Sold Separately:

		Width	Depth
24" Feet	Rectangle	34-48"	23-24"
	Equal Corner	40-48" × 40-48"	23-24"
30" Feet	Rectangle	46-48" × 46-48"	29-30"
		34-36" × 34-36"	29-30"
	120 Degree	40-42" × 40-42"	29-30"
		46-48" × 46-48"	29-30"

## Tools Required:

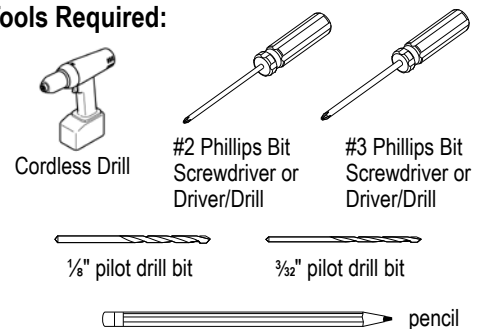

## SAVE THESE INSTRUCTIONS

**⚠ WARNING:** Maximum equipment loading of table assembly in addition to specified top is as follows:

- Maximum Top Weight: 83 lb (37.6 kg)
- Maximum Equipment Load: 200 lb (90.9 kg)

Loading should be evenly distributed over table surfaces.

**V = 120 VAC, 60 Hz / 5 A maximum**

**FLAMMABILITY:** All worksurfaces used must meet UL 962 flammability requirements

- Flame Spread Rating maximum 200
- Smoke Developed Index maximum 450

**WORKSURFACE MATERIAL:** This frameset is designed to accommodate worksurfaces made from Industrial Particle Board with nominal thickness of 1.125". If the worksurface is not appropriate or not mounted correctly to the table, it could cause the complete table to be unstable, it may collapse, and for an adjustable table, the electrical components may fail.

**Intended for indoor use only.**

**For commercial use only.**

### IMPORTANT SAFETY INSTRUCTIONS:

When using an electrical furnishing, basic precautions should always be followed, including the following:

Read all instructions before using this Ascent4 Work Center.

**DANGER:** To reduce the risk of electric shock, always unplug this Ascent4 Work Center from the electrical outlet before cleaning or servicing.

**⚠ WARNING:** To reduce the risk of burns, fire, electric shock, or injury to persons:

1. Unplug from outlet before putting on or taking off parts.
2. Close supervision is necessary when this furnishing is used by, or near children, invalids, or disabled persons.
3. Use this Ascent4 Work Center only for its intended use as described in these instructions, do not use attachments not recommended by the manufacturer.
4. Never operate this Ascent4 Work Center if it has a damaged cord or plug, is not working properly, has been dropped or damaged, or dropped into water. Return the furnishing to a service center for examination and repair.
5. Keep the cord away from heated surfaces.
6. Do not operate outdoors.
7. Do not operate where aerosol (spray) products are being used or where oxygen is being administered.
8. Use only SJT Type 18/2 AWG Cord.
9. To disconnect, remove plug from outlet.
10. Do not exceed maximum load recommendations.

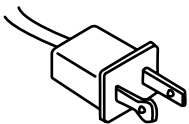

**Polarized Plug**  
Figure A

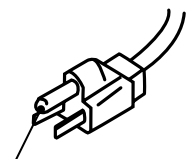

**Grounding Pin**  
Figure B

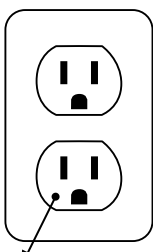

**Grounded Outlet**  
Figure C

**Polarized Plug Instructions** (Only applicable to products having a polarized plug power cord):

Some products include a polarized plug—see **Figure A** (One A/C plug blade wider than the other)—to reduce the risk of electrical shock. A polarized plug only fits a polarized power outlet one way. If the polarized plug does not fit properly into the electrical outlet turn the power plug over to see if it then fits properly and fully into the outlet. If the plug does still does not fit the outlet, contact a certified electrician to install the correct matching polarized electrical outlet.

**Caution:** Never modify the power cord plug in any way

**Double-Insulated Products Instructions:**

Some products are double-insulated. No means of grounding is required or provided on a double-insulated product; nor is a means for grounding to be added to the product. The plug in a double insulated system is shown in **Figure A**. Double-insulated products are indicated with markings of “double-insulated” or the “double box symbol”  or both.

**Grounding Instructions** (For grounded electric products only):

Products with grounded power cords are for use on a nominal 120 V circuit and has a grounded plug as shown in **Figure B**

Make sure the product is connected to an electrical outlet having the same configuration as the plug shown in **Figure C**.

**Caution:** Never modify, remove, or use adaptors that eliminate the ground connections from the grounded power cord

**A/C Power:**

Products sold in North America and other regions are 120 V A/C as marked on the power supply/control box of the furnishing and are to be used on a normal 120 V A/C circuit. Always follow the instructions above for power connection using grounded or double insulated power cords as supplied.

- Only use power cord(s) supplied with your electric product
- Never modify, alter, use an adaptor, or change the electrical system of this product in any way.

**Warning:** Doing so may cause risk of electrical shock or fire

*Illustration Disclaimer—Power Plug and Receptacle Images:*

*In some cases, the images in this instruction may not match the power cord supplied with your electrical furnishing based on your region. Plug type, blade size, and shape may change.*

# 1 Attach Brackets to Legs

**1.1** Attach Short Brackets (B) using M6 × 14 mm Flat Head Cap Screws (F) to both legs.

**1.2** Attach Left End Bracket (C) and Right End Bracket (D) to sides of the Leg (A) using M6 × 14 mm Flat Head Cap Screws (F).

**Note:** The Right End Bracket will be on your left and vice versa when the assembly is seen upside down.

**Tighten securely.**



To avoid stripping the threads, always insert and make the first few turns of the screw **BY HAND** with an Allen wrench (E), ensuring it is in straight.

Hardware at actual size

**F** M6 × 14 mm Flat Head Cap Screw

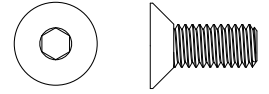

**Caution!**

Only use the M6 × 14 mm Flat Head Cap Screw (H) for assembly.

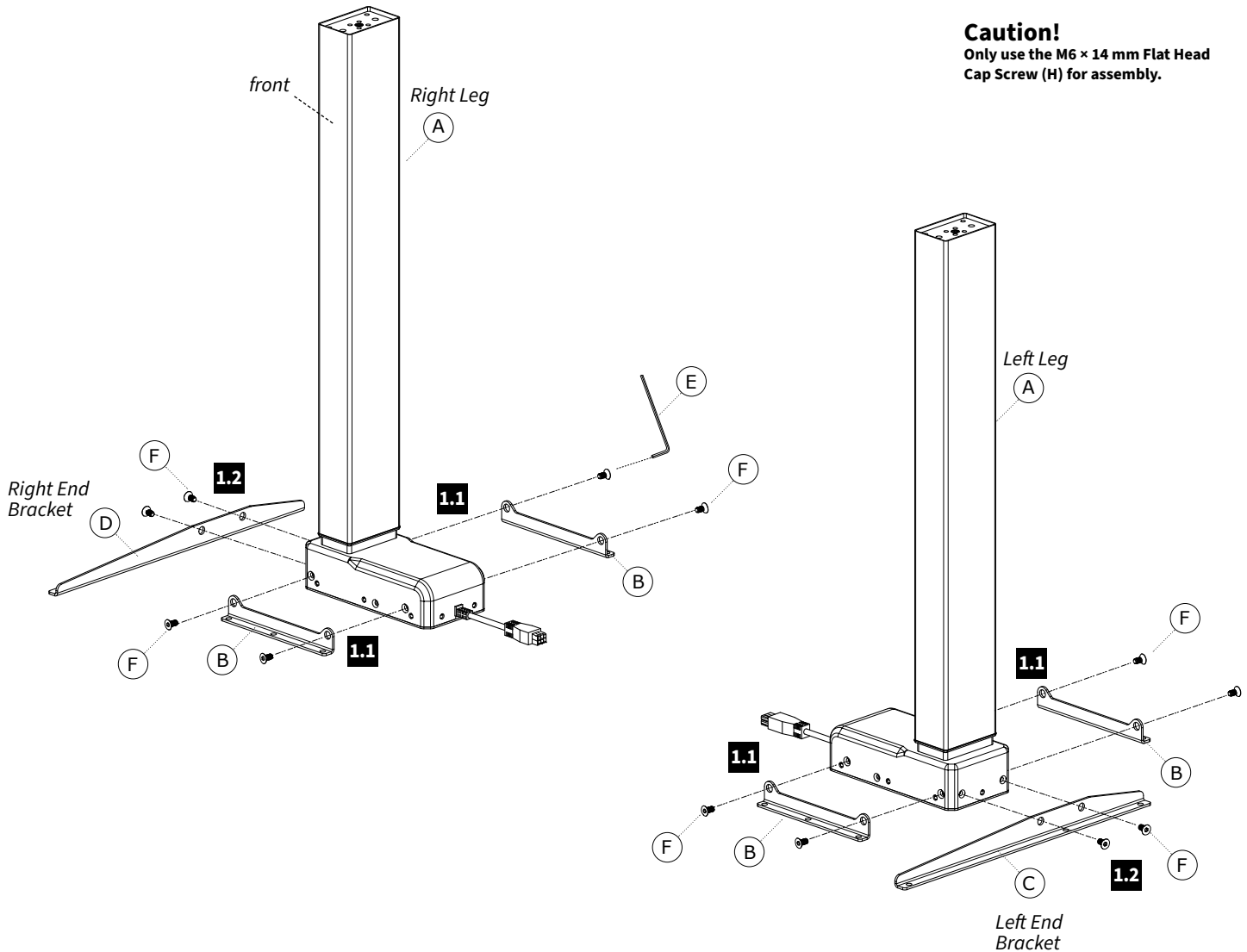

## 2 Attach Feet & Install Foot Glides

- 2.1 Install one (1) Foot (Q) to each leg using two (2) M8 × 18 mm Flat Head Cap Screws (H) and tighten securely with the 5 mm Allen Wrench (I).
- 2.2 Install Foot Glides (J) into each foot.

### Hardware at actual size

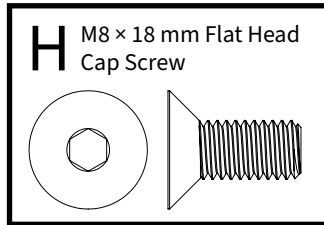

### Caution!

Only use the M8 × 18 mm Flat Head Cap Screw (H) for assembly.

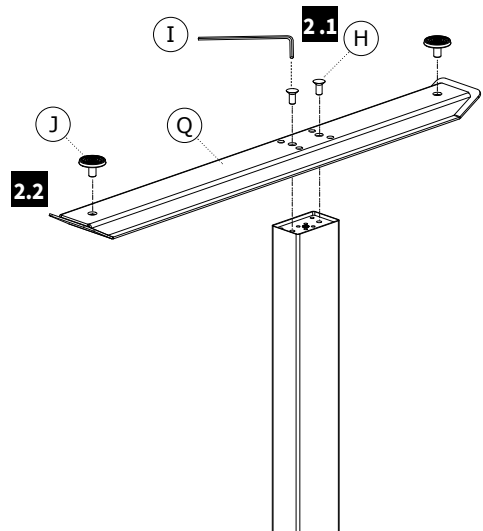

## 3 Attach Legs to Top

**Note:** For 2-Leg Corner and 120° Top Mounting Instructions, go to: [www.workriteergo.com/instructions](http://www.workriteergo.com/instructions)



### Note: Avoid trip or tip hazards!

For uniquely shaped, non-rectangular worksurfaces, it is the installer's responsibility to position the worksurface to minimize extended overhangs and position feet fully under the worksurface.

- 3.1 Position Leg Assembly 2.875" from the sides and 6.5" from the rear of the top, making sure the legs are parallel with the back edge of the top.
- 3.2 Use a 1/8" drill bit to drill pilot holes at the four corner locations. *We recommend marking your drill bit so you do not drill any more than 3/4" deep into your top.*  
**Be careful not to drill through your top!**

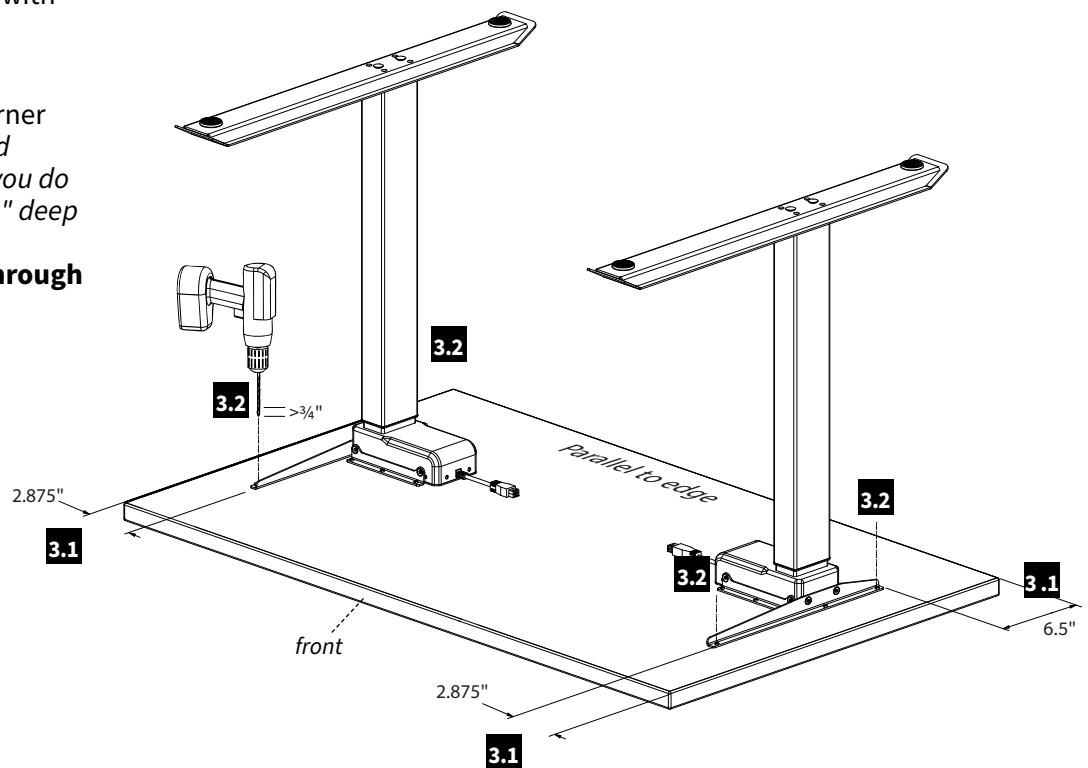

- 3.3** Install one (1) #12 × ¾" Pan Head Screw (G) into each of the four corner locations shown. **Note:** If using an electric drill to install the #12 screws, set the drill to the lowest torque setting to avoid overtightening and stripping the screws into the top.

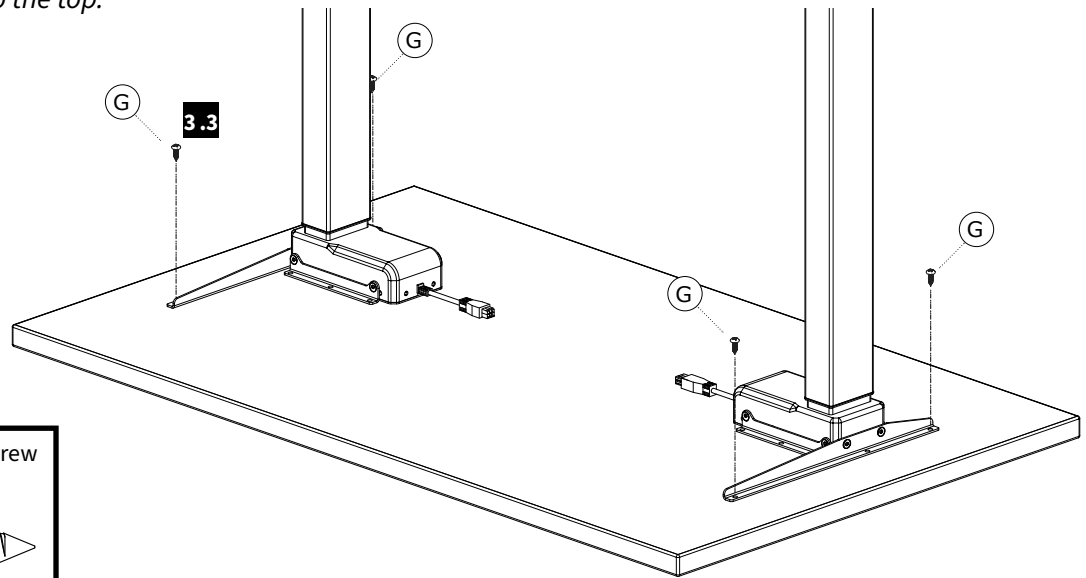

Hardware at actual size

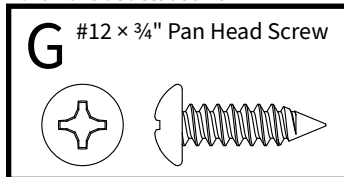

- 3.4** Drill all remaining pilot holes for the brackets into the top and install all remaining #12 × ¾" Pan Head Screws (G).

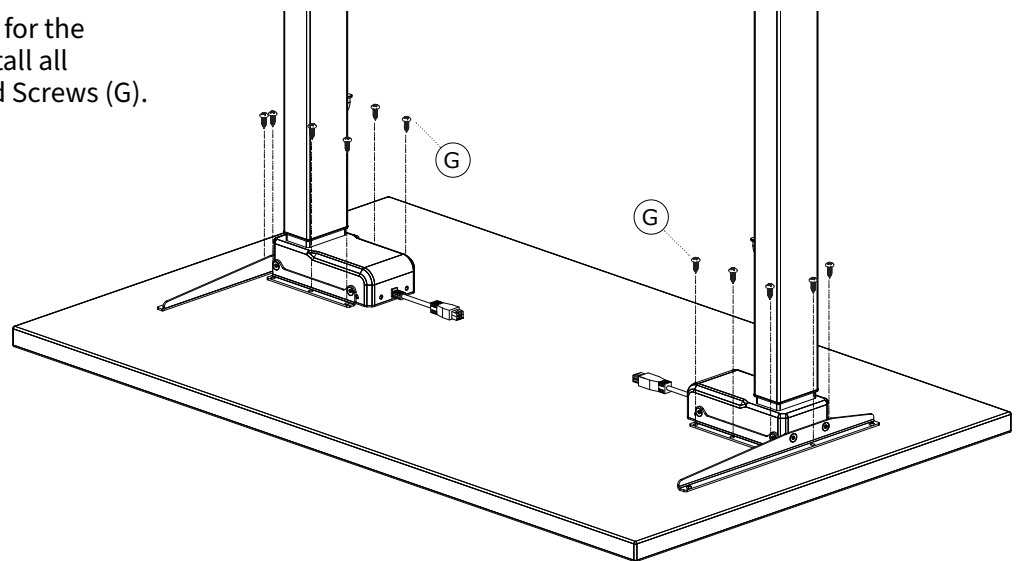

## 4 Attach Switch

- 4.1** Place the Switch (R) onto the top at the dimensions shown
- 4.2** Using your drill and a 3/32" drill bit, drill the switch mounting holes as shown.
- 4.3** Attach the Switch (R) with two (2) #8 × 5/8" Pan Head Screws (M)

Hardware at actual size

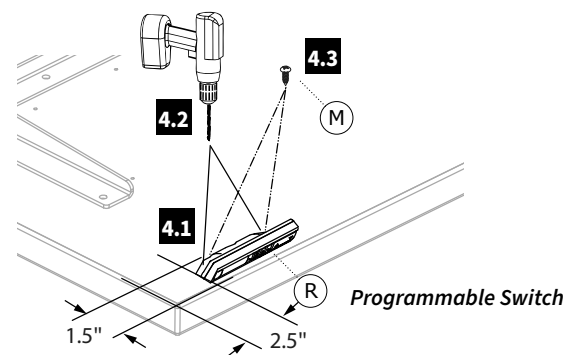
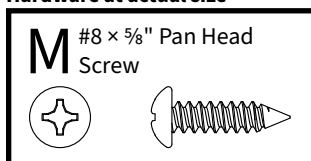

**Note:** Right hand location shown—the Switch (R) can be located on the right or left side of the table as required. The Control Box will need to be reversed in step 5 for left hand Switch mounting.

## 5 Attach Control Box to Worksurface

- 5.1 Place the Control Box (K) as shown with Motor Cable and Switch cable ports facing the right leg.
- 5.2 Plug the Right leg cable into the Control Box (K).
- 5.3 Using the control box as a guide, drill two pilot holes into the top using the 1/8" drill bit.  
**Be careful not to drill through your top!**
- 5.4 Mount the Control Box (K) to the top with two (2) #12 × 3/4" Pan Head Screws (G) and tighten securely.

*Note: Failure to tighten the control box to the desk securely will cause false collision detection resulting in the inability to adjust height properly. If this occurs, re-tighten the control box securely to the top.*

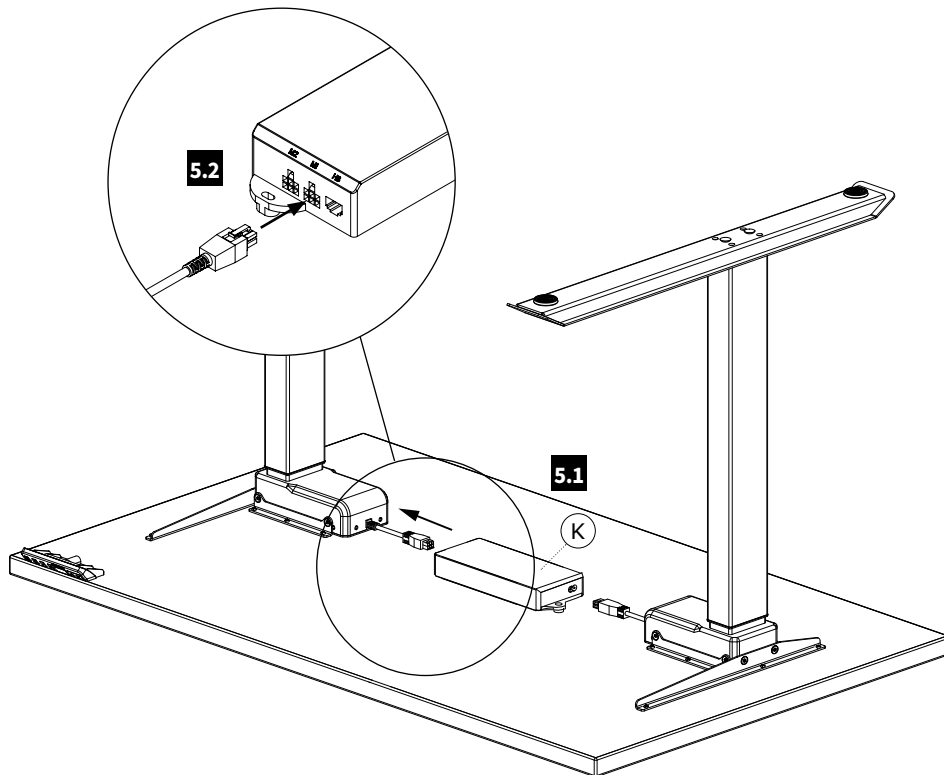

### **Left Hand Switch Note:**

**5.1 For Left Switch**—Place the Control Box (K) with motor cable and switch cable ports facing the Left leg.

**5.2 For Left Switch**—Plug the Left leg cable into the Control Box (K).

**Next**—Follow steps 5.3 and 5.4 above

### Hardware at actual size

**G** #12 × 3/4" Pan Head Screw

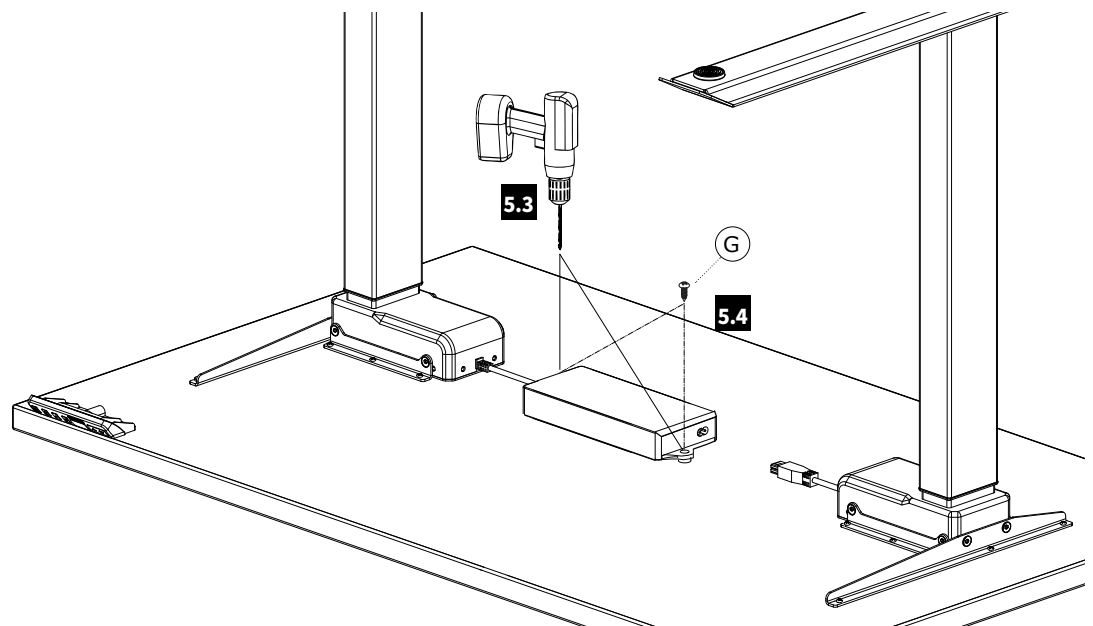
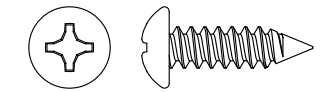

## 6 Install Motor Cable

- 6.1 Connect the Motor Cable (O) to the right end of the Control Box (K).  
*(Note: if you have mounted the switch on the left-hand side install the motor cable on the left end of the control box)*
- 6.2 Place one (1) Cable Spool (L) by the Control Box as shown.
- 6.3 Drill a  $\frac{1}{8}$ " pilot hole into the top and attach the Cable Spool (L) to the top with one (1) #12  $\times$   $\frac{3}{4}$ " Pan Head Screw (G) and tighten securely.  
**Be careful not to drill through your top!**
- 6.4 Wind the excess Motor Cable length around the Cable Spool and then connect the Motor Cable (O) to the Left leg cable.
- 6.5 Secure the motor cable neatly to the top with up to 3 Cable Loops (N) and one (1) #8  $\times$   $\frac{5}{8}$ " Pan Head Screw (M) per Cable Loop as required.

Hardware at actual size

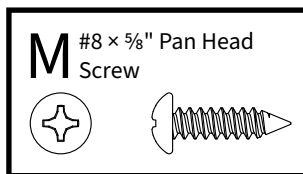

Hardware at actual size

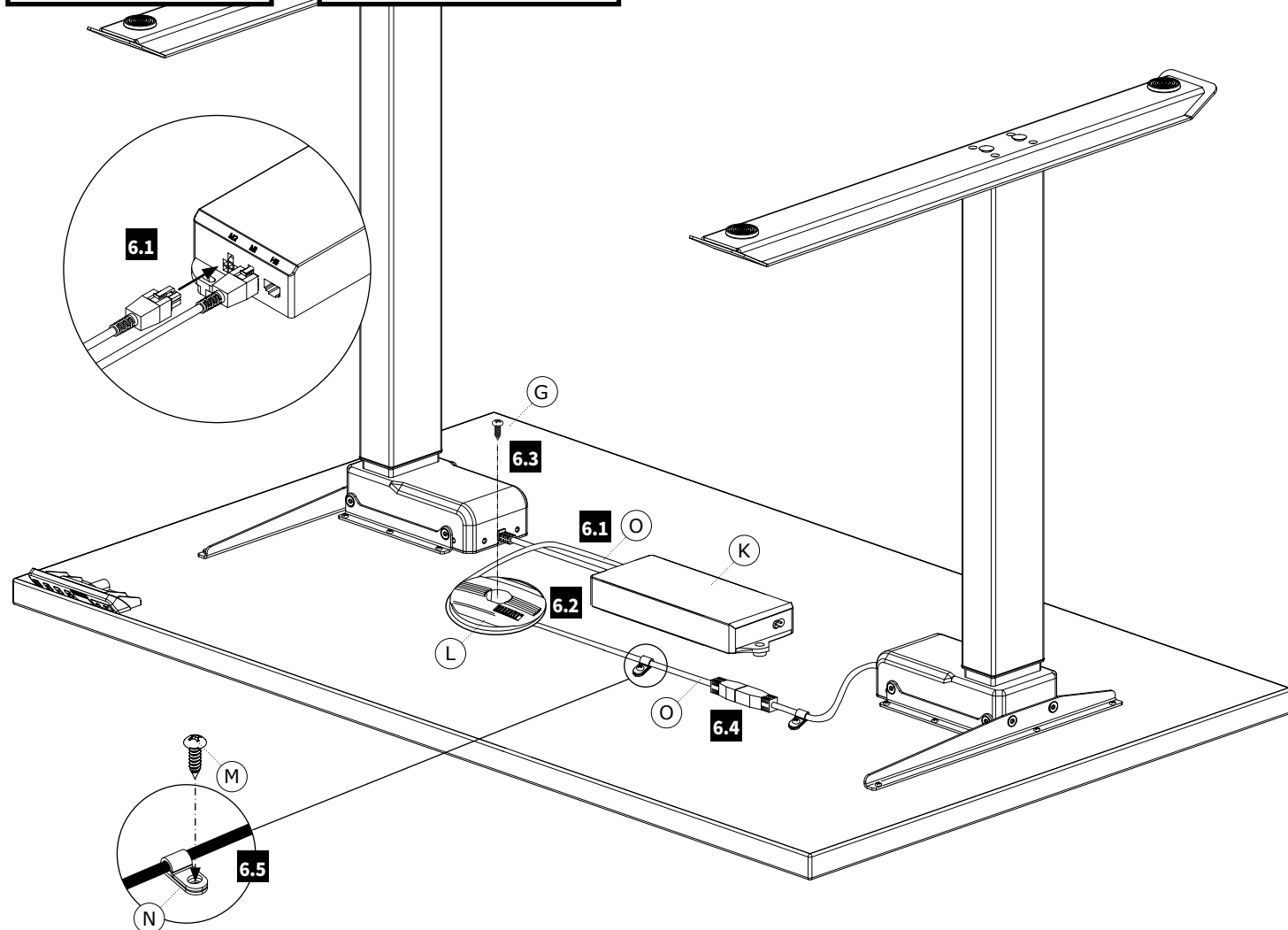
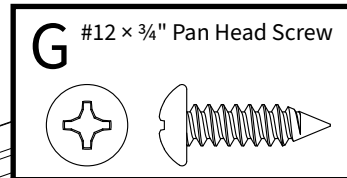

## 7 Plug-in the Switch Cable & Power Cord

**7.1** Route the Switch Cable back to the Control Box.

**7.2** Wind the excess Switch Cable length around the spool and then connect the Switch Cable (R) to the Control Box (K).

**7.3** Secure the Switch Cable to the top from the Switch to the Cable Spool with two (2) Cable Loops (N) and one (1) #8 × 5/8" Pan Head Screw (M) per Cable Loop as required.

**7.4** Plug the Power Cord (P) into the Control Box (K).

Hardware at actual size

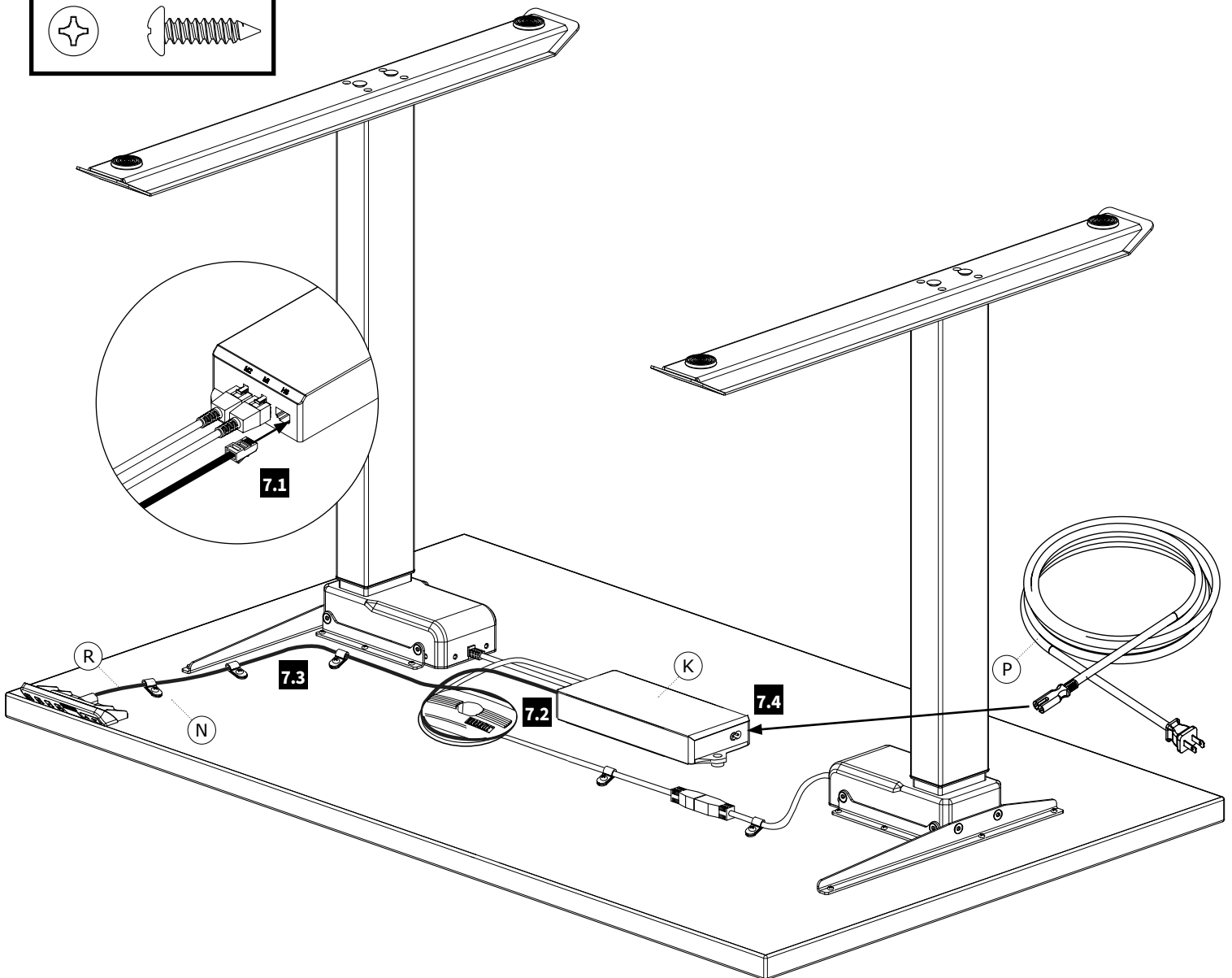
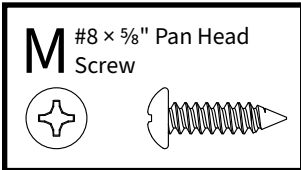



## 8 Turn Table Over & Power Up

- 8.1** Carefully turn the table over and upright onto its feet.  
*Note: Be careful not to damage the programmable switch when turning the table over*
- 8.2** Lift and carry the table into its location for use. Plug the table into power.

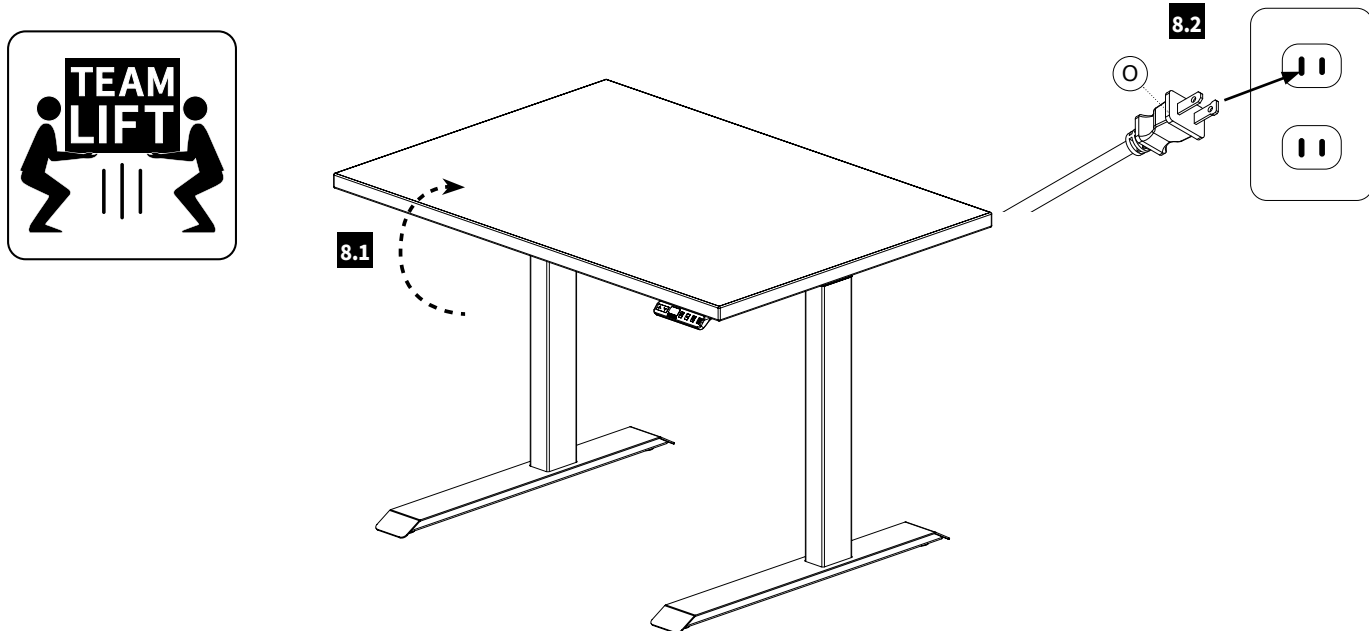

## 9 Adjust Feet Glides

If necessary, adjust the Foot Glides (J) on the feet to level the workstation. Thread out to increase height or thread in to decrease height as required.

## ✓ Cleaning Instructions

To clean the Ascent4 legs, apply cleaner to a soft cloth.

Suggested cleaners: Windex or Formula 409.

Do not use solvents and do not saturate or spray cleaners directly onto work center base.

## Programmable Switch

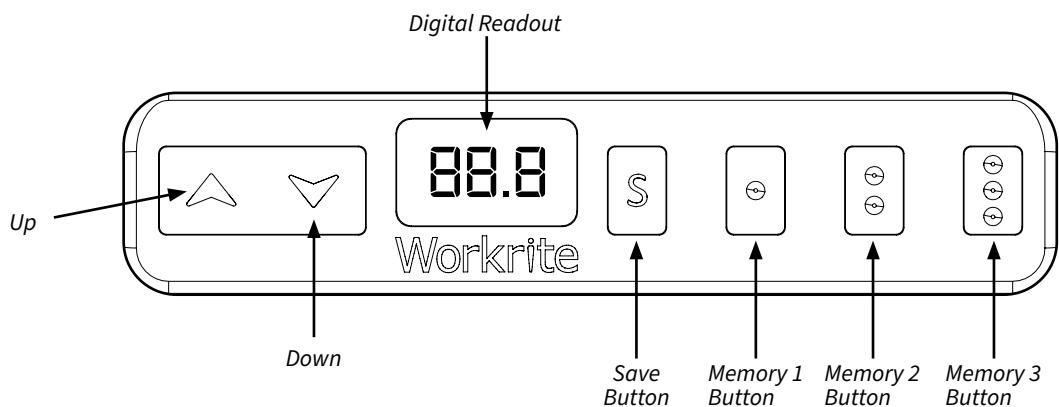





### Reset

After assembly an “Initialization/Reset” is required to make sure the table is synchronized and operates properly. Also, this table will indicate on the switch when a reset is required by displaying “RST”  on the digital readout.

To initialize or reset, press the Down ▼ button continuously until the table lower and returns to a stop. When this step is completed, you will hear a beep and the digital display will change from RST to the digital height readout. The table is now ready for use.

### Memory Height Settings

This table includes a convenient auto-move feature that when a memory setting is programmed and then used simply press the memory button once and the table will automatically move to the set position that was programmed to that button.

To set a memory press the up or down arrow and move your table to the desired height for seated or standing use. Next press the  button once and then immediately press button , , or . Repeat as required to set your next user height memory setting. Once completed simply press the desired button once and the table will automatically move to the memory preset height.

### User Settable Travel Height Limits

This table includes a special user feature to set travel limits of the table to avoid collisions with obstacles either above or below the desk by setting a movement limit in the control system of the table.

#### Lower Height Limit

To set a special travel height **LOWER** limit move the table down to the desired lower height. Next Press the **DOWN ▼** button and  button simultaneously and you will hear a beep. A lower limit has been set.

To remove a special travel height **LOWER** limit, move the table down using the **DOWN ▼** button until the table reaches the lower limit that was set. Next Press the **DOWN ▼** button and the  button simultaneously and you will hear a beep. The lower limit will now be removed.

#### Upper Height Limit



To set a special travel height **UPPER** limit move the table up to the desired upper height. Next Press the **UP ▲** button and the  button simultaneously and you will hear a beep. An upper limit has been set.

To remove a special travel height **UPPER** limit, move the table up using the **UP ▲** button until the table reaches the upper limit that was set. Next Press the **UP ▲** button and the  button simultaneously and you will hear a beep. The upper limit will now be removed.

### Lock Feature

This table includes a lock feature to lock the table from inadvertent use or movement while away from the desk.

To set a lock feature press both the **UP and DOWN ▲▼** buttons simultaneously until you hear a beep. Once locked the display will read “LOC” indicating the table has been locked.

To unlock the table, press the memory buttons  then  and then  and you will hear a beep indicating the table has been unlocked. Once unlocked the display will no longer read “LOC” and the digital display returns to normal.